

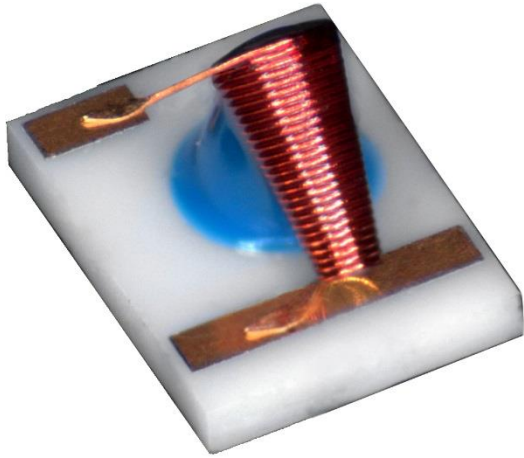

Micro CCM Broadband Conical Inductor

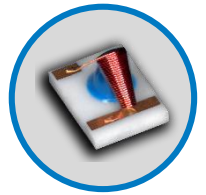

- Substrate Mounted For Chip & Wire Applications
- Broadband performance to 40 Ghz
- Integrated 50Ω Microstrip
- Low Insertion Loss -.35 dB
- Perfect for Bias Tee Applications

Micro CCM Conical Inductor Specification

Part Number	L (uH)	I max (mA)	Upper Freq. Limit (GHz) Typ.	Return Loss (dB) Typ.	Insertion Loss (dB) Typ.	Q Typ. @ 10 MHz	DCR Typ (Ohms)	Wire Size (AWG)	Foot Print (L x W) Inch	Figure
CCM7T44-001	.024	500	40	-20	-.35	20-25	.090	44	.060 x .060	A
CCM10T47-003	.070	340	40	-26	-.35	25-30	.390	47	.060 x .060	A
CCM10T40-001	.047	1000	40	-20	-.35	15-20	.070	40	.060 x .080	B
CCM20T44-001	.170	325	40	-20	-.35	22-28	.300	44	.060 x .080	B
CCM24T45-001	.250	275	40	-26	-.35	20-25	.500	45	.060 x .080	B
CCM25T47-003	.250	230	40	-26	-.35	25-30	.800	47	.060 x .080	B

Custom Conical Assemblies available upon request - Contact Piconics for more info.

S-Parameters available @ www.piconics.com/conical-inductors

Environmental:

Operating Temp.	-55°C to +155°C
Storage Temp.	-55°C to +155°C
RoHS Compliant	Yes
Outgas	Meets ASTM E595 (Special Epoxy Required)
FIT Rate	34 SR-332
MSL Rating	1
MTBF	29,695,225 Hours

Frequency Response:

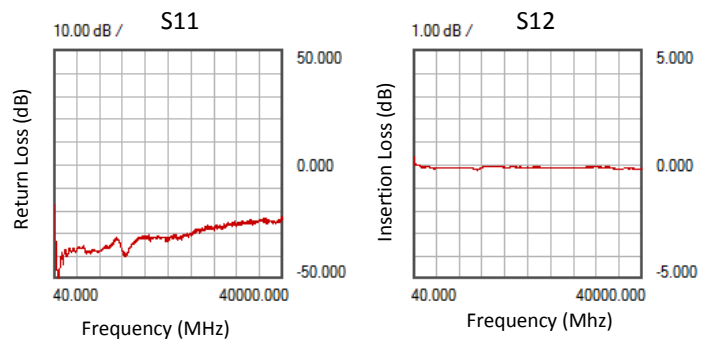

www.piconics.com

ISO 9001:2008

Established 1963

26 Cummings Road | Tyngsboro, MA 01879 | P: 978-649-7501 | sales@piconics.com



Mechanicals:

Not Drawn To Scale
Dimensions in Inches

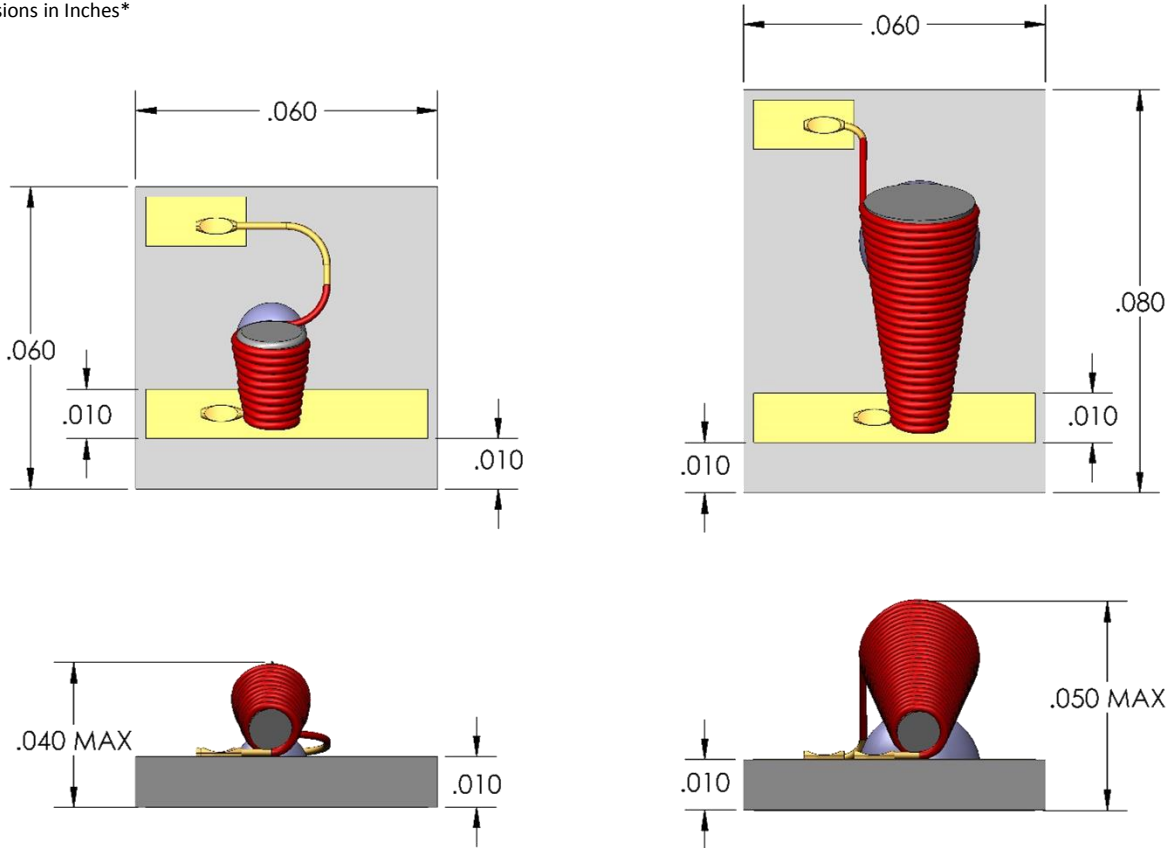

Figure: A

Figure: B

Substrate:

Material	99.6 % Alumina
Metallization - Front side	TiW/Au/Ni/Au
Metallization - Backside	TiW/Au/Ni/Au

Packaging:

Package Type	Gel Pak
Quantity / Pack	50

Notes:

1. L & Q are measured on an HP 4286A Rf Impedance Analyzer using probes.
2. I_{dc} Max is the DC current at which the device sees a 100°C temperature rise over an ambient temperature of 25°C.
3. Please see "Conical Frequency Range Measurement Document" to see process for determining the inductors frequency range.

Mounting:

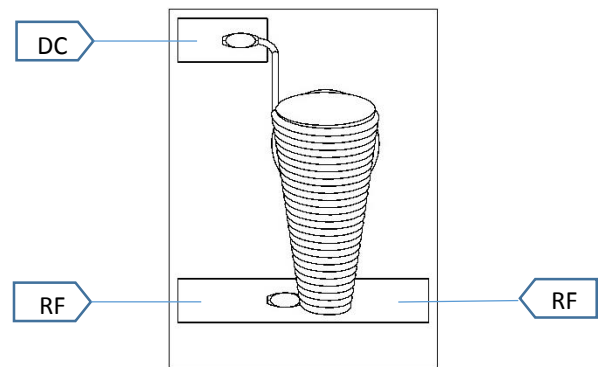

Wire Bond For Connection