



The Waveguide Solution



*Tect Electronics*

*The authorized distributor in the Greater China Region*

## Waveguide Attenuators

Fixed Attenuators

FA SERIES

Variable Attenuators

VA SERIES

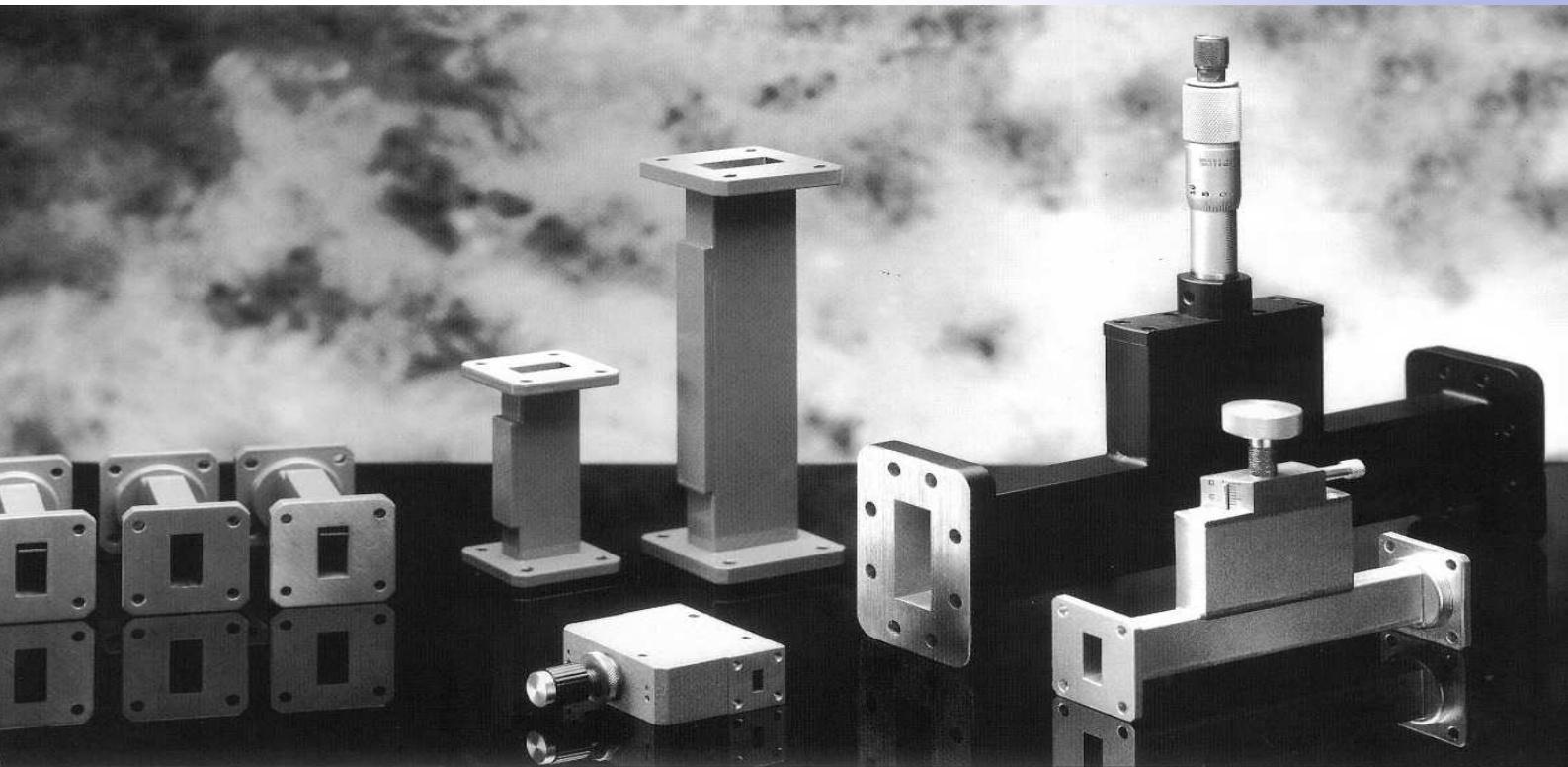

The Waveguide Solution offers a range of Low Power Fixed and Infinitely Variable Attenuators as well as the range of Laboratory Standard Precision Variable Attenuators. All items are of compact design and are manufactured from Brass as standard although Copper and Aluminium versions are available upon request. The FA and VA series of attenuators are manufactured to the highest quality standards. Attenuators are manufactured with the full range of International Flange Styles as shown in The Waveguide Solution Flange Catalogue and can be offered with alternative plated finishes on request. All The Waveguide Solution Attenuators are offered with attractive, hardwearing, epoxy paint finish. The Waveguide Solution facility is approved to ISO 9001: 2000.

## Waveguide Attenuators

The Waveguide Solution has developed and manufactured an extensive range of Waveguide Attenuators. These are Low Power Fixed Attenuators, Low Power Variable Attenuators and a range of Precision Variable Attenuators.

### Fixed Low Power attenuators

All of the standard fixed attenuators listed are manufactured from selected waveguide tube. The attenuating element is manufactured from a metallised glass fibre reinforced PTFE, resistive card vane or an absorptive composite material. The vane version is supported in the waveguide using two metal rods and is accurately positioned to give a desired value between 0 and 40dB as required. The composite absorber is positioned and glued into the tube (the attenuation is based on the length of the absorber). In order to offer the

optimum performance with cost, TWS offers 2 different models for each frequency range.

### Variable Attenuators

Based upon the same construction as the Low Power Fixed Attenuators, the metallised glass fibre reinforced PTFE resistive card vane is positioned in the Waveguide using a backlash free, spring controlled piston, precisely fitted in a machined housing to give a high degree of mechanical stability. The attenuation is varied by means of a knurled finger-control knob, and a locking screw is provided for repetitive measurements, or, in the case of the variable precision devices, the attenuation is varied by means of a standard micrometer drive.

For the WG22 version, a guillotine principle is used for the vane insertion into the broadwall of the waveguide. Movement of the vane is achieved by the means of an eccentric cam attached to the control knob.

## FIXED ATTENUATOR (Range 0-40 dB)

### Standard Rectangular

Specification:

Material: Brass

Finish: Blue Paint, Silver Plated Flanges

Full Band Flatness: Nominal 10% of attenuator value\*

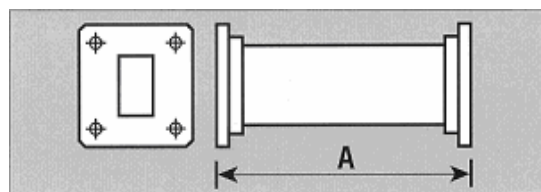

Operating Frequency Band (GHz)	Waveguide Designation			TWS PART NUMBER	Max V.S.W.R.	Max Power Watts C.W.	Overall Length "A" (mm)
	UK WG	IEC R	E.I.A. WR				
2.60 – 3.95	10	32	284	FA 10 –SQB- (***)-(**)	1.10	4	330
3.30 – 4.90	11A	40	229	FA 11A –SQB- (***)-(**)	1.10	4	406
3.95 – 5.85	12	48	187	FA 12 –SQB- (***)-(**)	1.12	4	305
4.90 – 7.05	13	58	159	FA 13 –SQB- (***)-(**)	1.12	3	280
5.85 – 8.20	14	70	137	FA 14 –SQB- (***)-(**)	1.12	2	241
7.05 – 10.0	15	84	112	FA 15 –SQB- (***)-(**)	1.13	1	203
8.20 – 12.40	16	100	90	FA 16 –SQB- (***)-(**)	1.13	1	152
10.0 – 15.0	17	120	75	FA 17 –SQB- (***)-(**)	1.14	1	152
12.4 – 18.0	18	140	62	FA 18 –SQB- (***)-(**)	1.14	0.7	127
15.0 – 22.0	19	180	51	FA 19 –SQB- (***)-(**)	1.15	0.7	127
18.0 – 26.5	20	220	42	FA 20 –SQB- (***)-(**)	1.15	0.5	102
26.5 – 40.0	22	320	28	FA 22 –SQB- (***)-(**)	1.20	0.5	102

\* Better flatness value can be achieved for narrow band application.

\*\*Attenuation Fixed according to customer requirements at any value within the overall attenuation range.

\*\*\* For 3 Digit Rectangular Flange part number, refer to the TWS Flange catalogue, or consult the factory.

Attenuation calibration accuracy better than  $\pm 0.35$  db at the centre frequency

Ordering: when ordering, please state the attenuation value and frequency.

## FIXED ATTENUATOR (Range 0-40 dB)

### Double Ridge

#### Specification:

Material:	Aluminium Alloy
Finish:	Blue Paint, Iridited / Chromated Flanges
Full Band Flatness:	Contact factory for details

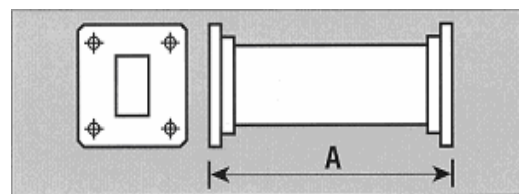

Operating Frequency Band (GHz)	Waveguide Designation	TWS PART NUMBER	Max V.S.W.R.	Max Power Watts C.W.	Overall Length "A" (mm)
6.5 – 18.0	WRD650 D28	FA 650 –CQH- (**-**-**-)-A-(**)	1.15	0.7	152
7.5 – 18.0	WRD750 D24	FA 750 –CQH- (**-**-**-)-A-(**)	1.15	0.7	152
18.0 – 40.0	WRD180 C24	FA 180 –CQH- (**-**-**-)-A-(**)	1.25	0.5	51

\*\*Attenuation Fixed according to customer requirements at any value within the overall attenuation range.  
 \*\*\* For 3 Digit Rectangular Flange part number, refer to the TWS Flange catalogue, or consult the factory.

Attenuation calibration accuracy better than  $\pm 0.6$  db at the centre frequency

+ Please contact factory for availability

Ordering: When ordering please state the attenuation value and operating frequency range

## VARIABLE ATTENUATOR (Range 0-40 dB)

### Standard Rectangular

#### Specification:

Material:	Brass
Finish:	Blue Paint, Silver Plated Flanges
Attenuation Elements:	Resistive Card
Insertion Loss:	Less than 0.3 dB
Full Band Flatness:	Contact factory for details

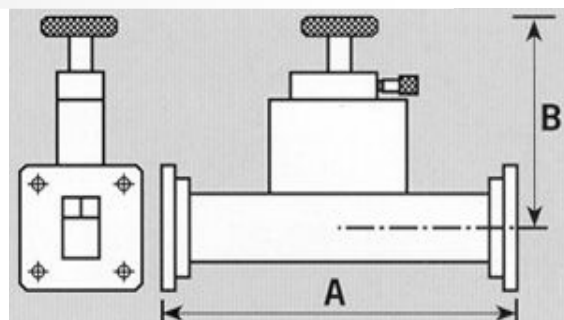

Operating Frequency Band (GHz)	Waveguide Designation			TWS PART NUMBER	Max V.S.W.R.	Max Power Watts C.W.	Overall Length "A" (mm)	Dim "B" (mm)
	UK WG	IEC R	E.I.A. WR					
++2.60 – 3.95	10	32	284	VA 10 –SQB- (**-**-**-)-B	1.10	4	330	178
3.30 – 4.90	11A	40	229	VA 11A –SQB- (**-**-**-)-B	1.10	4	406	171
3.95 – 5.85	12	48	187	VA 12 –SQB- (**-**-**-)-B	1.12	4	305	76
++4.90 – 7.05	13	58	159	VA 13 –SQB- (**-**-**-)-B	1.12	3	279	102
5.85 – 8.20	14	70	137	VA 14 –SQB- (**-**-**-)-B	1.12	2	241	105
7.05 – 10.0	15	84	112	VA 15 –SQB- (**-**-**-)-B	1.13	1	203	89
8.20 – 12.40	16	100	90	VA 16 –SQB- (**-**-**-)-B	1.13	1	152	89
10.0 – 15.0	17	120	75	VA 17 –SQB- (**-**-**-)-B	1.14	1	152	87
12.4 – 18.0	18	140	62	VA 18 –SQB- (**-**-**-)-B	1.14	0.7	127	76
15.0 – 22.0	19	180	51	VA 19 –SQB- (**-**-**-)-B	1.15	0.7	127	76
18.0 – 26.5	20	220	42	VA 20 –SQB- (**-**-**-)-B	1.15	0.5	102	70
26.5 – 40.0	22	320	28	VA 22 –SQB- (**-**-**-)-B	1.20	0.5	51	60

\*\*\* For 3 Digit Rectangular Flange part number, refer to the TWS Flange catalogue, or consult the factory.

Attenuation calibration accuracy better than  $\pm 0.35$  db at the centre frequency

++ Please contact factory for availability

## VARIABLE PRECISION ATTENUATOR (Range 0-40 dB)

### Standard Rectangular

Specification:

Material:	Brass
Finish:	Blue Paint, Silver Plated Flanges
Attenuation Elements:	Resistive Card
V.S.W.R.:	Better than 1.25 dB
Insertion Loss:	Less than 0.2 dB
Resetting Accuracy:	±0.01 dB
Flatness:	Contact factory for details

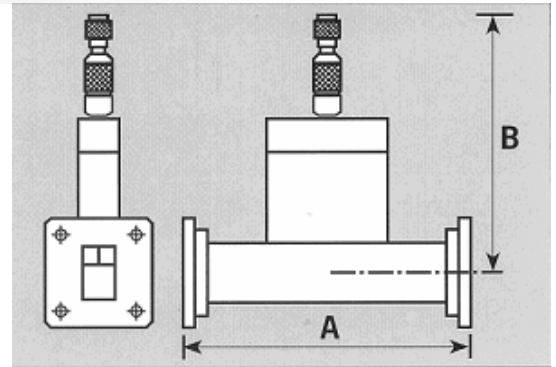

Operating Frequency Band (GHz)	Waveguide Designation			TWS PART NUMBER	Max Power Watts C.W.	Micro-meter Resolution dBs/div Average	Overall Length "A" (mm)	Dim "B" (mm)
	UK WG	IEC R	E.I.A. WR					
++2.60 – 3.95	10	32	284	VA 10 – PQB- (***)- (***)-B	4	0.01	330	267
3.30 – 4.90	11A	40	229	VA 11A – PQB- (***)- (***)-B	4	0.02	406	194
3.95 – 5.85	12	48	187	VA 12 – PQB- (***)- (***)-B	4	0.02	305	219
++4.90 – 7.05	13	58	159	VA 13 – PQB- (***)- (***)-B	3	0.02	279	200
5.85 – 8.20	14	70	137	VA 14 – PQB- (***)- (***)-B	2	0.03	241	165
7.05 – 10.0	15	84	112	VA 15 – PQB- (***)- (***)-B	1	0.04	203	165
8.20 – 12.40	16	100	90	VA 16 – PQB- (***)- (***)-B	1	0.05	152	127
10.0 – 15.0	17	120	75	VA 17 – PQB- (***)- (***)-B	1	0.05	152	127
12.4 – 18.0	18	140	62	VA 18 – PQB- (***)- (***)-B	0.7	0.07	127	120
18.0 – 26.5	20	220	42	VA 20 – PQB- (***)- (***)-B	0.5	0.10	102	113
26.5 – 40.0	22	320	28	VA 22 – PQB- (***)- (***)-B	0.2	0.07	51	90

\*\*\* For 3 Digit Rectangular Flange part number, refer to the TWS Flange catalogue, or consult the factory.

### CALIBRATION

3 Frequencies in Band	0 – 10 dB ± 0.07 dB
1 dB Steps to 10 dB	10 – 20 dB ± 0.1 dB
2 dB Steps to 20 dB	20 – 30 dB ± 0.2 dB
5 dB Steps to 40 dB	30 – 40 dB ± 0.25 dB

### CALIBRATION ACCURACY

++ Please contact factory for availability

## Ordering Information

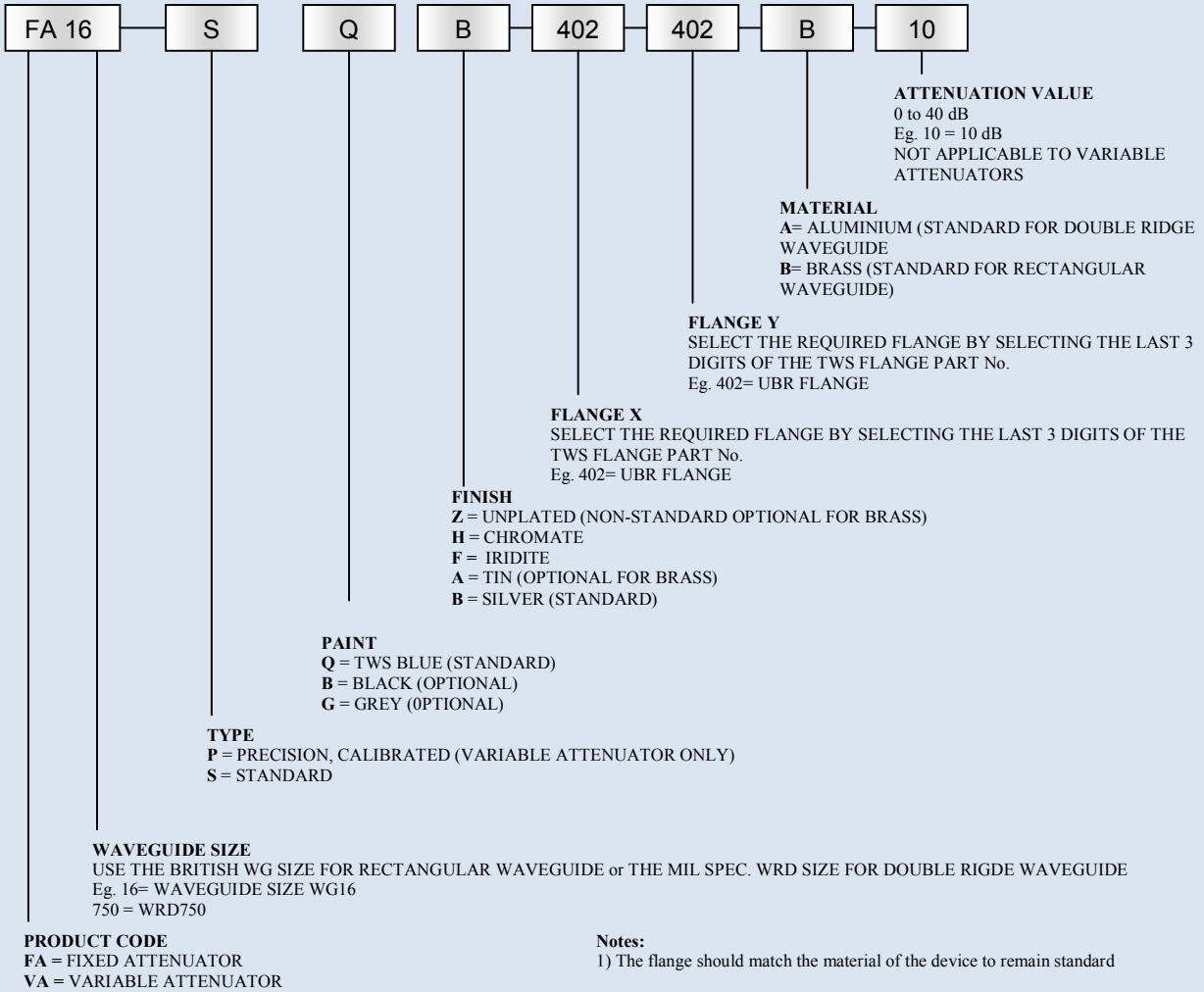

For assistance selecting RoHS compliant options please contact the factory



## The Waveguide Solution

### The Waveguide Solution Limited

King Charles Business Park • Old Newton Road • Heathfield • Newton Abbot  
Devon TQ12 6UT • United Kingdom

T: +44 (0) 1626 835255

F: +44 (0) 1626 836166

E-mail: [enquiries@waveguidesolution.co.uk](mailto:enquiries@waveguidesolution.co.uk)  
[www.waveguidesolution.co.uk](http://www.waveguidesolution.co.uk)

Specifications shown on this document are offered as a guide only. Components may be modified to suit the mechanical or electrical parameters requested, or may be optimized to suit the operating frequency range. Frequency range of operation shall be advised when ordering. RoHS compliant products are available.

Information provided in this brochure is for reference only. Dimensions or specifications are typical values. All designs, specifications and availabilities of products and services presented in this document may be subject to change without notice. For confirmation of details please consult your agent or manufacturer. Issue 1.0a